



## Research Report

# Impaired pre-saccadic shifts of attention in neglect patients



Joris A. Elshout <sup>a,\*</sup>, Tanja C.W. Nijboer <sup>a,b</sup> and Stefan Van der Stigchel <sup>a</sup>

<sup>a</sup> Experimental Psychology, Helmholtz Institute, Utrecht University, Utrecht, the Netherlands

<sup>b</sup> Center of Excellence for Rehabilitation Medicine, Brain Center Rudolf Magnus, University Medical Center Utrecht, Utrecht University and De Hoogstraat Rehabilitation, Utrecht, the Netherlands

## ARTICLE INFO

## Article history:

Received 31 March 2020

Reviewed 29 June 2020

Revised 30 September 2020

Accepted 1 May 2021

Action editor Jason Mattingley

Published online 23 June 2021

## Keywords:

Neglect

Attention

Eye movements

Pre-saccadic

## ABSTRACT

Every saccade is generally preceded by a mandatory shift of attention to the saccade endpoint, allowing us to process visual information more effectively. Whether this 'pre-saccadic shift of attention' is still intact in hemispatial neglect is unknown. Whereas neglect patients exhibit lateralized impairments of attention and often show impaired saccadic behaviour, it is not yet clear how the pre-saccadic shift of attention is affected during accurately executed eye movements. In this study, we used a gaze contingent visual discrimination task, in which neglect patients had to discriminate a probe presented before saccade onset. Results revealed an imbalance in discrimination performance between the two hemifields with poor performance to probes in the contralesional compared to the ipsilesional hemifield when accounting for saccadic impairments. These results suggest that attention and eye movements are both unique impairments of neglect patients. We hypothesize that the impaired pre-saccadic shift of attention could be one of the key problems of neglect and might underlie other spatial and non-spatial deficits often reported in neglect patients.

© 2021 The Authors. Published by Elsevier Ltd. This is an open access article under the CC BY license (<http://creativecommons.org/licenses/by/4.0/>).

## 1. Introduction

Humans are remarkably fast in shifting attention towards relevant visual locations (Deubel, 2008; Montagnini & Castet, 2007). During visual exploration of our world, attention is known to be allocated to the location of an upcoming saccade. This so called 'pre-saccadic shift of attention' allows us to process visual information more effectively during visual

exploration (Rolfs et al., 2011; Zhao et al., 2012). The influential Pre Motor Theory of attention (PMT) even proposes that shifting spatial attention is functionally equivalent to planning a goal directed action (Rizzolatti et al., 1987). This theory was recently criticized by Smith and Schenk who suggested that, although the same neural circuits might be involved, separate populations of cells could still be responsible for attention processing and motor preparation (Smith & Schenk, 2012). They proposed that a dissociation between eye

\* Corresponding author. Heidelberglaan 1, 3584 CS, Utrecht, the Netherlands.

E-mail address: [j.a.elshout@uu.nl](mailto:j.a.elshout@uu.nl) (J.A. Elshout).

<https://doi.org/10.1016/j.cortex.2021.05.019>

0010-9452/© 2021 The Authors. Published by Elsevier Ltd. This is an open access article under the CC BY license (<http://creativecommons.org/licenses/by/4.0/>).

movement preparation and shifting attention may be specifically related to endogenous attention—a voluntary shift based on top-down aims and intentions— and not to exogenous attention in which visual information in the environment captures attention in a bottom-up reflexive fashion.

Many studies have shown this tight link between attention and eye movements in healthy populations (Deubel & Schneider, 1996; Hanning et al., 2018; Jonikaitis & Deubel, 2011). The coupling between eye movement preparation and attention is often studied using the dual task paradigm developed by Deubel and Schneider (Deubel & Schneider, 1996). In this task, participants have to maintain fixation on a central fixation cross until a colored arrow cue (blue, red or green) is presented pointing towards the left or right. Three colored ovals are placed on the left and right from fixation and the participant has to saccade towards the oval that matches the cues color and indicated direction as soon as the cue disappears. Digital number eights are placed within each oval. During the saccade preparation time, a probe (digitized E or 3) is briefly flashed on either the saccade target location, or one of the two movement irrelevant locations, while the other locations also change identity (digitized 2 or 5). Critically, the probe is masked when the eyes land on the target. Deubel and Schneider showed that probe discrimination is significantly better at the saccade target location compared to the movement irrelevant locations and that the covert attention shift prior to saccade execution is obligatory.

An interesting approach to study this coupling between eye movements and attention is to examine patients with visuospatial neglect. Visuospatial neglect is defined as a failure to report, respond to or orient to stimuli presented in the contralesional hemifield in the absence of sensory or motor defects (Heilman & Valenstein, 1979). The core of this disorder reflects a lateralized impairment of attention towards the contralesional hemifield (Danckert & Ferber, 2006; Marshall & Halligan, 1989). Interestingly, it has been shown that most neglect patients are still able to execute eye movements accurately towards (salient) targets in the contralesional hemifield (Behrmann et al., 2001; Van der Stigchel & Nijboer, 2010). Therefore, patients with neglect offer an ideal population to study the coupling between attention and eye movements.

Previous studies have provided evidence for impaired spatial remapping (Duhamel et al., 1992; Pisella & Mattingley, 2004; Saj et al., 2020; Vuilleumier et al., 2007) and deficits in visual spatial working memory (Husain et al., 2001; Malhotra et al., 2004; Saj et al., 2020) in patients with neglect. However, no studies have focused on the pre-saccadic shift of attention in neglect patients, which may be one of the underlying problems of these deficits, as these pre-saccadic shifts are crucial for successful spatial remapping and visual spatial working memory across saccades (Van der Stigchel & Hollingworth, 2018). In the absence of a successful pre-saccadic shift of attention, the saccade target is not automatically transferred to visual working memory before the saccade. Accordingly, processes which depend on the correct storage of the saccade target in visual spatial working memory, such as spatial remapping, might be impaired.

So far, only a few (case) studies on patients with *optic ataxia* have studied pre-saccadic shifts of attention in stroke

patients (Blangero et al., 2010; Khan et al., 2009; Striemer et al., 2007). Interestingly, Khan et al. found a dissociation between saccade execution and pre-saccadic shifts of attention in a single patient with optic ataxia using a simplified version of the task developed by Deubel and Schneider (Khan et al., 2009). In this version, the patient had to execute a saccade as soon as the cue was presented towards the central location of the three ovals at either side. Although this patient was able to correctly execute saccades towards a visual target in the contralesional hemifield, the patient could not identify pre-saccadically presented probes in the contralesional hemifield suggesting that saccade preparation and pre-saccadic perception can be dissociated. In contrast, a subsequent study with a different patient with optic ataxia performing the same task did not reveal such a dissociation as performance on the probe identification task for probes presented in the contralesional hemifield was similar to the ipsilesional hemifield (Blangero et al., 2010). Therefore, there still is limited evidence of a possible dissociation between saccade execution and pre-saccadic shift of attention after stroke. In order to test this coupling more fundamentally, a study with a larger sample of stroke patients with lateralized attentional deficits is needed.

The aim of the current study was to investigate the association between attention and saccadic eye movements in a group of thirteen neglect patients. In a gaze contingent paradigm, we tested whether neglect patients are able to discriminate a probe, presented pre-saccadically thus relying on the pre-saccadic shift of attention, in the ipsi- and contralesional hemifield. If accurate eye movements of neglect patients towards the contralesional hemifield are not preceded by an attentional shift, this may help to understand why many patients do not benefit from visual scanning training (Bowen et al., 2013) which builds on the premises that attention can be trained by initiating movements towards the contralesional visual field, alluding to the link between attention and the oculomotor system. In addition, the results of this study may help to understand deficits in spatial remapping and visual spatial working memory, often reported in this patient group.

---

## 2. Materials and methods

We report how we determined our sample size, all data exclusions (if any), all inclusion/exclusion criteria, whether inclusion/exclusion criteria were established prior to data analysis, all manipulations, and all measures in the study.

### 2.1. Participants

Thirteen patients with visuospatial neglect after stroke were included during admittance to the Hoogstraat Rehabilitation center. This was the maximum feasible within the time window of data collection. With an estimated effect size of .8 and alpha of .05, this led to a power of .75. The patients were selected based on presence of neglect assessed during a neuropsychological neglect screening that all stroke patients in the Hoogstraat Rehabilitation center receive as part of usual care, including digitized shape cancellation, digitized line

bisection and Catherine Bergego Scale (CBS). With respect to the digitized shape cancellation task, the number of omitted items on the contralesional side were subtracted from the number of omission on the ipsilesional side, which resulted in an omission difference. An omission difference deviating more than 2.5 SD from the average score of a control dataset -consisting of 25 age-matched healthy participants-was considered neglect. The same dataset of healthy controls contained performance during the line bisection task and was used to calculate the cutoff score on the digitized line bisection task. Patients were included if 1) at least one of these three tests were deviant from normal range (i.e.,  $\geq 2$  omission difference at shape cancellation test,  $\geq 2$  of 4 lines deviant on line bisection task or CBS score  $\geq 6$ ), 2) the neglect was caused by stroke, age between 18 and 85 and (3) they had sufficient ability to comprehend and to communicate as assessed by a psychologist. Patients with traumatic head injury, severe aphasia (lack of understanding and/or production of speech) and/or insufficient understanding of the task as assessed by a psychologist prior to inclusion were not included. Written informed consent was obtained from all patients according to the Declaration of Helsinki. The study was evaluated and approved by the Medical Ethical Committee of University Medical Centre Utrecht (16–640/C, NL64626.041.18).

## 2.2. Visual discrimination task

An adopted version of the visual discrimination task first described in Deubel and Schneider (1996) was used to test the pre-saccadic shift of attention. The original version could not be performed by the neglect patients, as it was too complex due to the inclusion of additional conditions. Therefore, we developed a simplified version in which six black ovals were presented on a grey background, three on the right and three on the left of the central fixation cross (Fig. 1). All six possible target locations were masked by a digital grey number eight. Using an EyeLink 1000 (SR

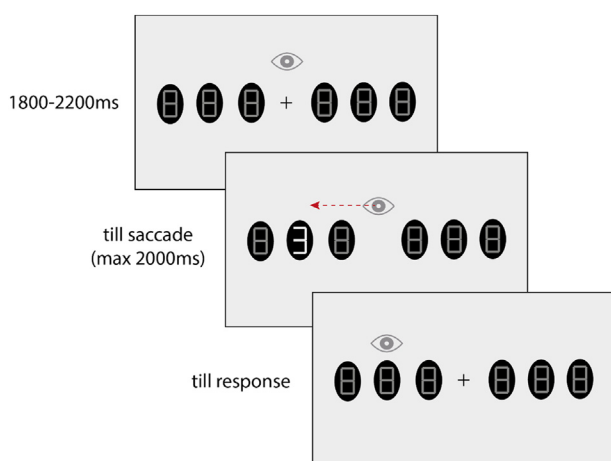

**Fig. 1 – Visual discrimination task.** The central items on each side were presented at 10 deg visual angle from fixation at the center and the items were 4 deg separated. **Note,** probe presentation time is variable and similar as the saccade latency as it is coupled to saccade execution.

Research Ltd Ottawa ON) and gaze contingent software, one of the six targets was replaced by a salient probe (i.e., white digital “E” or digital “3”, counterbalanced for identity and location), when patients fixated for  $2 \pm .2$  s at the central fixation cross. The other items did not change identity. The patients were instructed to saccade to the item that was replaced by the probe and make a force choice response whether an E or 3 was presented by pressing the right and left arrow key to the keyboard, respectively. Importantly, when the EyeLink system detected a saccade, the probe was masked again by the digital eight. Therefore, the probe was never present when the eyes landed on the target location (confirmed after offline analysis, see analyses section).

Importantly, as a consequence of this gaze contingent paradigm, we correct for the expected difference in saccade latency between the left and right hemifield (Van der Stigchel & Nijboer, 2010): the probe is presented till the saccade is initiated.

On 11% of the trials, the probe was not masked after saccade detection and presented till response (max 2sec), to allow patients to detect the probe. This was implemented to keep the patients motivated and to check retrospectively whether they understand task instruction. For each patient, we collected data in 2 runs of 108 trials (of which 12 post saccadic per run).

## 2.3. Analyses

Although a gaze contingent paradigm was used, we checked offline whether the probe was masked before the eyes landed on the target location. First, all post saccadic trials (probe still visible after the saccade) were analyzed to confirm that patients were able to perform the task. Next, we selected the pre-saccadic trials in which saccades were made to the correct side, had an amplitude  $>3$  deg and landed on target location after the probe was masked. The targets closest to fixation were placed at 4 deg from fixation and are 1 deg in width. Therefore, we considered an amplitude of at least 3deg as a goal directed saccade. Trials without a saccade or with a saccade latency  $>2000$  ms were excluded. Finally, for each patient we calculated the percentage correct responses, saccade latencies and landing accuracy per hemifield. In addition, we will perform a binned analysis on landing accuracy to study how performance is affected by landing accuracy. Repeated measures ANOVA will be used to compare performances between hemifields (two-tailed, alpha set to .05). Mixed model binary logistic regression analyses will be used to compare performance between both hemifields while taking saccade latency and amplitude error into account. Lastly, a step-wise multiple regression analysis will be used to study the relationship between neglect severity and pre saccadic discrimination performance. No part of the study procedures or analysis plans was preregistered prior to the research being undertaken.

## 3. Results

All patients included were able to complete the task. However, based on the analysis of the post saccadic trials, one patient

was removed from further analysis since his performance on these post saccadic trials was around chance level (43.4% correct) which suggest a lack of task comprehension. In the twelve included patients (ten left sided neglect), 66% of all trials were kept (61% contralesional side and 71% ipsilesional side). Trials were excluded when no saccade was detected by the Eyelink system (15% contralesional vs 11% ipsilesional), saccade latency >2000 ms (9% contralesional vs 1% ipsilesional), the saccade landed prior to masking (6% contralesional vs 2% ipsilesional), amplitude <3 deg (2% contralesional vs 3% ipsilesional) or a combination of errors (7% contralesional vs 12% ipsilesional). Note that overall fewer (accurate) saccades were executed towards the contralesional hemifield compared to the ipsilesional hemifield. For this study, in which we investigate the pre-saccadic shift of attention, we focus on the saccades that were executed correctly. Demographic and clinical characteristics of the remaining twelve patients can be found in Table 1.

3.1. Probe identification performance

The percentage of accurate discrimination on the post-saccadic trials (i.e., accurate probe identification when probe was still presented after saccade landing on target) was 87.9% (SE = 3.83) in the contralesional hemifield and 92.4% (SE = 2.83) in the ipsilesional hemifield and did not differ (F (1,10) = 1.18, p = .30,  $\eta_p^2 = .10$ ).

However, neglect patients' performance on the pre-saccadic trials (i.e., accurate probe identification on trials in which the probe was masked before saccade landed on the target) was significantly lower for the contralesional hemifield compared to the ipsilesional hemifield (F (1,11) = 6.93, p = .02,  $\eta_p^2 = .39$ ; Fig. 2A). While performance in the ipsilesional hemifield was 77.5% correct, it is significantly reduced to 63.8% correct in the contralesional hemifield.

3.2. Saccade latencies

We found a much longer saccade latency to the contralesional hemifield (570 ± 88 ms) relative to the ipsilesional hemifield (271 ± 12 ms) (F (1,11) = 9.74, p = .01,  $\eta_p^2 = .47$ ; Fig. 2B). Hence, it is important to recall that we accounted for this difference in saccade latency by presenting the probe up to saccade execution using a gaze contingent paradigm. Therefore, the saccade must have been planned within the probe presentation period. Thus, even with a longer probe presentation time, as long as the saccade latency, performance was still significantly lower for the contralesional hemifield compared to the ipsilesional hemifield.

3.3. Landing accuracy

Importantly, unsigned landing accuracy was not different between the contra- (1.66 ± .14 deg) and ipsilesional hemifield (1.82 ± .13 deg) (F (1,11) = .85, p = .38,  $\eta_p^2 = .07$ ; Fig. 2C). This was also not significant if signed landing error positions were analyzed (contralesional: -.67 ± .22 deg; ipsilesional: .04 ± .34 deg, (F (1,11) = 3.39, p = .09,  $\eta_p^2 = .24$ ). In addition, an analysis on the performance binned to absolute amplitude error revealed

Table 1 – Demographical and clinical characteristics.

Subject	Gender	Age (years)	Time post stroke (days)	Aetiology	Side neglect	MoCA	Barthel Index	Star Cancellation (omission difference)	Line Bisection (# lines deviant <sup>a</sup> )	CBS
N1	M	51	14	haemorrhage	L	26	20	2	2	2
N2	M	55	23	ischemic	L	22	4	0	2	11.7
N3	M	62	18	ischemic	L	26	15	3	3	21.3
N4	F	37	20	ischemic	L	21	2	0	2	10
N5	F	48	25	haemorrhage	L	22	6	22	0	10
N6	M	66	19	ischemic	L	24	11	11	4	28.6
N7	F	57	36	ischemic	L	23	6	23	3	26.7
N8	M	67	24	ischemic	R	21	8	4	0	6
N9	F	53	89	Subarachnoid haemorrhage	L	22	3	0	3	13
N10	M	60	61	ischemic	L	n/a	6	0	4	10
N11	M	67	20	ischemic	L	23	9	4	3	21.25
N12	F	44	40	ischemic	R	n/a	n/a	10	3	14
Mean (SE)		55.6 (2.7)	32.4 (6.4)			23.0 (.53)	8.2 (1.6)	6.6 (2.4)	2.4 (.4)	14.5 (2.4)

<sup>a</sup> Out of four different lines randomly repeated eight times.

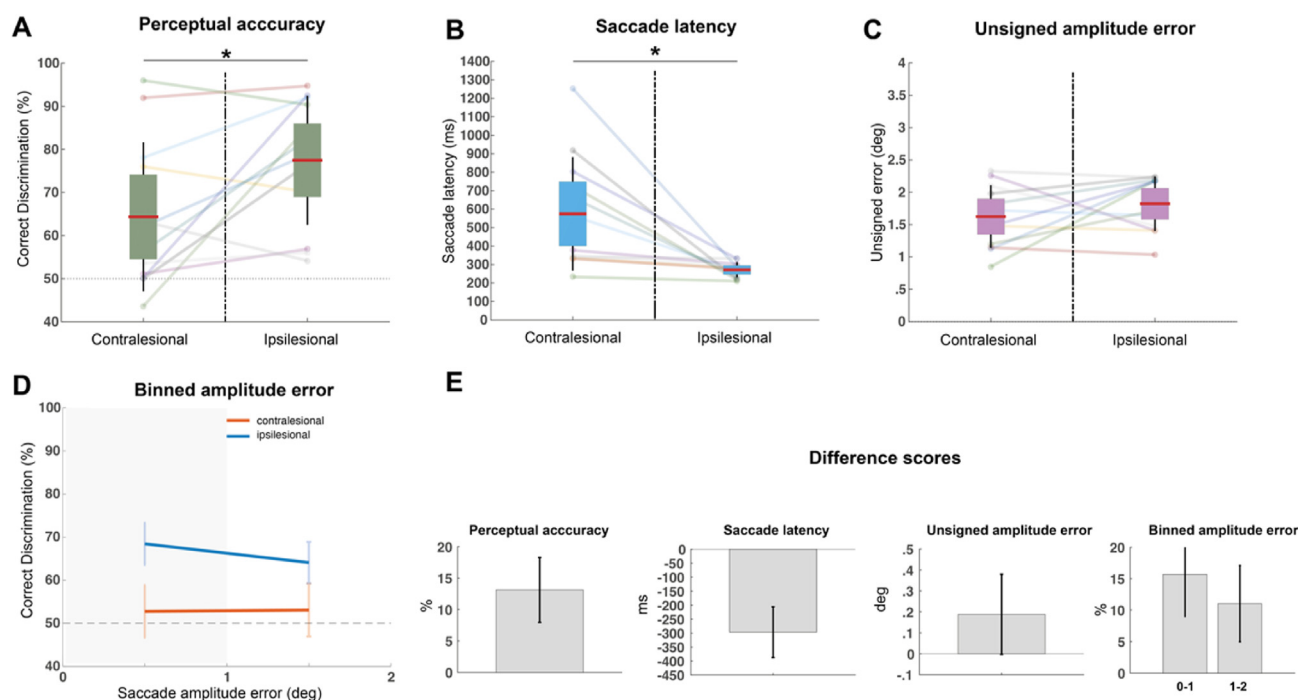

**Fig. 2 – Performance on the visual discrimination task.** The red lines in panels A–C reflect the mean, the colored areas are the 95% confidence interval and the black lines represent the standard deviation. The individual performances are plotted with shaded lines in panels A–C. **A)** Performance during pre-saccadic trials. The dotted horizontal line at 50% reflects chance level. **B)** Saccade latencies. **C)** Unsigned amplitude error. **D)** Correct discrimination performance as a function of amplitude error (bins: 0–1 deg; 1–2 deg). **E)** Difference scores for each outcome measure presented in panel 2A, B, C and D. The error bars represent the SE.

a main effect of saccade side ( $F(1,11) = 6.82, p = .024, \eta_p^2 = .38$ ) with better performance in the ipsilesional side for these bins than performance in the contralesional side, and no main effect of amplitude error ( $F(1,11) = .23, p = .64, \eta_p^2 = .02$ ). Thus, performance does not decrease with larger amplitude errors (Fig. 2D). There was no interaction between saccade side and amplitude error ( $F(1,11) = .37, p = .55, \eta_p^2 = .03$ ).

The difference scores (ipsilesional–contralesional) of performance, saccade latency and unsigned landing error are plotted in Fig. 2E.

Finally, a stepwise mixed model binary logistic regression analysis with side, saccade latency and landing accuracy as fixed factors and patient as random factor, revealed a significant main effect for side ( $\beta = .32, t = 2.28, p = .023$ , odds ratio = 1.37), saccade latency ( $\beta = -.001, t = -3.45, p = .001$ , odds ratio = 1) and landing accuracy ( $\beta = -.09, t = -2.36, p = .018$ , odds ratio = .91) as well as the random factor patient (estimate = .623  $Z = 2.13, p = .03$ ). Together, our data indicate an impaired pre-saccadic shift of attention on top of impaired saccadic behaviour, suggesting that the pre-saccadic shift of attention is a unique aspect of the neglect disorder above and beyond the impaired saccadic behaviour.

On a final note, if all analyses were performed including all trials, similar results are found that lead to the same conclusions

(discrimination performance contralesional 63.7% vs 75.7% ipsilesional;  $F(1,11) = 8.61, p = .014, \eta_p^2 = .44$ ).

### 3.4. Individual performances

The patterns of individual neglect patients are important to investigate the generalizability and/or heterogeneity of neglect in relation to pre-saccadic shifts of attention. As can be deduced from Fig. 2A, six of the twelve patients show a minor imbalance between contralesional and ipsilesional hemifield (between 2.5%–9.1%), while six of the patients actually show a strong imbalance (between 13.9%–42.3%). To investigate whether the amount of imbalance between contralesional and ipsilesional performance on the visual discrimination task was related to severity of neglect, we conducted a step-wise multiple regression analysis. Therefore, we regressed the imbalance difference score of the visual discrimination task (% correct ipsilesional–% correct contralesional) on the performance on shape cancellation task (omission difference), line bisection task (number of lines deviant from normal range; this simple metric (instead of e.g., reporting one mean mm deviation) is used to provide an easy to understand quick overview of task performance of all lines) and CBS score (Fig. 3). The model was a significant predictor of

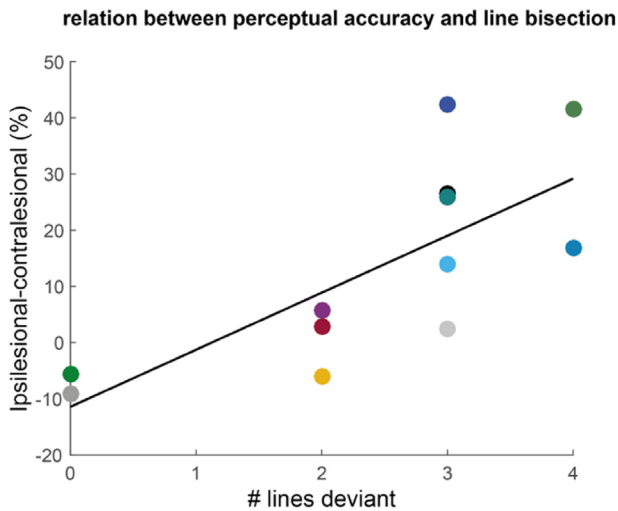

**Fig. 3 – Relation between perceptual accuracy during the visual discrimination task and performance on line bisection task. The difference between contralesional and ipsilesional performance on the visual discrimination is plotted on the y-axis and regressed against the number of lines that were deviant from normal range.**

the imbalance score of the visual discrimination task ( $F(3,8) = 7.51, R^2 = .64, p = .01$ ). While performance on the line bisection task contributed significantly to the model ( $B = 1.215, p = .002$ ), the shape cancellation task and CBS did not ( $B = .546, p = .06$  and  $B = -.629, p = .07$ , respectively). Removing the non-significant predictors stepwise led to the final model with only the line-bisection task as contributing predictor ( $F(1,10) = 12.49, R^2 = .56, B = .75, p = .005$ ). This analysis indicates that the more severe the neglect based on the line-bisection task, the more disrupted the pre-saccadic shift of attention.

#### 4. Discussion

Here, we show for the first time that the pre-saccadic shift of attention during correctly executed saccades may be impaired in neglect patients. On top of impaired saccadic behaviour in the contralesional field, there may be additional deficits in the shift of attention to the saccade endpoint before an eye movement is initiated and accurately executed. Such an impaired pre-saccadic shift of attention in neglect patients may underlie other deficits often associated with neglect such as spatial remapping (Pisella & Mattingley, 2004; Vuilleumier et al., 2007) and visual spatial working memory (Saj et al., 2018; Van der Stigchel & Hollingworth, 2018). If an eye movement is not preceded by an attentional shift, specific features of an object of the upcoming saccade endpoint are not encoded into visual spatial working memory (Van der Stigchel & Hollingworth, 2018). This lack of a trans-saccadic representation will make the visual system less efficient and may lead to perceptual deficits in learning and anticipation to sequential visual events in the contralesional hemifield (Saj et al., 2018). In addition, our results are not in line with the PMT that proposes that eye movements and attention are functionally equivalent (Rizzolatti et al., 1987). While it might still

be that eye movements and attention are tightly coupled in the healthy brain, our data suggest that impaired pre-saccadic attention is a unique aspect of the neglect disorder on top of saccadic impairments.

Our gaze contingent paradigm allowed us to control for potential longer saccade latencies towards the contralesional hemifield. As many studies have shown that the saccade latencies to the contralesional hemifield are longer in neglect patients (Behrmann et al., 2001; Harvey et al., 2002; Van der Stigchel & Nijboer, 2010), we anticipated that a fixed probe presentation time may result in a presentation period that is too short for the patient to plan the saccade. Indeed, saccade latencies were longer to the contralesional hemifield compared to the ipsilesional hemifield. Even though we presented the probe as long as the saccade latency, which was often  $>500$  ms, there was still an attentional impairment in the contralesional hemifield. This finding also eliminates the possibility that covert attention was already present at the saccade endpoint. If the task could have been performed by using covert attention solely (i.e., attention not coupled to an eye movement), performance should have been equal for both visual fields (Blangero et al., 2010).

Another potential explanation for the reduced performance in the contralesional hemifield is the existence of potential visual field defects. However, since the target was randomly presented at three different target locations at each side, 4 deg spaced, one would expect a larger amplitude error than observed ( $-.67$  deg in contralesional side;  $1.66$  deg unsigned) in case of a visual field defect. In addition, we removed all trials with saccade latencies  $>2000$  ms or no saccade at all, excluding trials in which the probe onset is likely missed. Therefore, we are confident that the patients were able to detect the probe presentation at the target location.

Not all twelve neglect patients in our study seem to show an impairment in the pre-saccadic shift of attention and oculomotor programming, consistent with the known heterogeneity of visuospatial neglect (Bowen et al., 2002, 2013; Van der Stigchel & Nijboer, 2018). An impaired pre-saccadic shift of attention is therefore not a behavioural signature of visuospatial neglect perse, although it seems related to the severity of neglect based on the line bisection task: the more severe the neglect on this task, the more disrupted the pre-saccadic shift of attention.

Our results may have important implication for rehabilitation of neglect. Visual scanning therapy (VST), in which eye movements are trained to more actively explore the contralesional hemifield, is widely used to ameliorate symptoms of neglect. Currently it is hard to predict rehabilitation outcome for neglect patients; not all patients benefit from this extensive rehabilitation method (Bowen et al., 2013; Kerkhoff & Schenk, 2012). We speculate that a poor rehabilitation outcome with VST may be caused by a disrupted link between attention and eye movements to the contralesional hemifield. Neglect patients with an impaired pre-saccadic shift of attention may have less training potential as the eye movement system cannot be used to covertly shift attention to the contralesional hemifield, as postulated by the PMT. It would be interesting to study whether our hypothesis is valid in future studies where neglect patients also receive VST. Moreover, whether this

disrupted link can be restored by visual training, also remains an open question.

Together, our study has several important implications: the impaired pre-saccadic shift of attention in neglect patients may 1) be one of the key problems related to other deficits often reported in neglect (e.g., spatial remapping, visual spatial working memory), 2) predict rehabilitation success of patients trained with VST, and 3) suggest that eye movements and attention are not functional equivalent, as predicted by the PMT.

---

## Funding

This work was supported by the Dutch Research Council (NWO) Open Area grant 464-15-112 to S.v.d.S.

---

## Data availability

The conditions of our ethics approval do not permit archiving or sharing of the data obtained in this study with any individual outside the author team under any circumstances. Materials for the study that can be shared are publicly available at <https://osf.io/u2qkz/>.

---

## Open practices

The study in this article earned an Open Materials badge for transparent practices. Materials will be provided upon reasonable request.

---

## Authors contributions

All authors contributed to experimental design. JE collected and analyzed the data. All authors were involved in writing and reviewing the manuscript.

---

## Declaration of competing interest

All authors declare that they have no competing interests.

---

## Acknowledgements

We thank A. Eijsackers, M. Wilms and I. den Ouden for help with patient inclusion. We thank M. Naber for help with the analyses.

---

## REFERENCES

- Behrmann, M., Ghiselli-Crippa, T., & Dimatteo, I. (2001). Impaired initiation but not execution of contralesional saccades in hemispatial neglect. *Behavioural Neurology*, *13*, 39–60.
- Blangero, A., Khan, A. Z., Salemme, R., Deubel, H., Schneider, W. X., Rode, G., Vighetto, A., Rossetti, Y., & Pisella, L. (2010). Pre-saccadic perceptual facilitation can occur without covert orienting of attention. *Cortex; a Journal Devoted To the Study of the Nervous System and Behavior*, *46*, 1132–1137.
- Bowen, A., Hazelton, C., Pollock, A., & Lincoln, N. B. (2013). Cognitive rehabilitation for spatial neglect following stroke. [The Cochrane Database of Systematic Reviews Electronic Resource], CD003586.
- Bowen, A., Lincoln, N. B., & Dewey, M. (2002). Cognitive rehabilitation for spatial neglect following stroke. [The Cochrane Database of Systematic Reviews Electronic Resource], CD003586.
- Danckert, J., & Ferber, S. (2006). Revisiting unilateral neglect. *Neuropsychologia*, *44*, 987–1006.
- Deubel, H. (2008). The time course of presaccadic attention shifts. *Psychological Research*, *72*, 630–640.
- Deubel, H., & Schneider, W. X. (1996). Saccade target selection and object recognition: Evidence for a common attentional mechanism. *Vision Research*, *36*, 1827–1837.
- Duhamel, J. R., Goldberg, M. E., Fitzgibbon, E. J., Sirigu, A., & Grafman, J. (1992). Saccadic dysmetria in a patient with a right frontoparietal lesion. The importance of corollary discharge for accurate spatial behaviour. *Brain: a Journal of Neurology*, *115*(Pt 5), 1387–1402.
- Hanning, N. M., Aagten-Murphy, D., & Deubel, H. (2018). Independent selection of eye and hand targets suggests effector-specific attentional mechanisms. *Scientific Reports*, *8*, 9434.
- Harvey, M., Olk, B., Muir, K., & Gilchrist, I. D. (2002). Manual responses and saccades in chronic and recovered hemispatial neglect: A study using visual search. *Neuropsychologia*, *40*, 705–717.
- Heilman, K. M., & Valenstein, E. (1979). Mechanisms underlying hemispatial neglect. *Annals of Neurology*, *5*, 166–170.
- Husain, M., Mannan, S., Hodgson, T., Wojciulik, E., Driver, J., & Kennard, C. (2001). Impaired spatial working memory across saccades contributes to abnormal search in parietal neglect. *Brain: a Journal of Neurology*, *124*, 941–952.
- Jonikaitis, D., & Deubel, H. (2011). Independent allocation of attention to eye and hand targets in coordinated eye-hand movements. *Psychological Science*, *22*, 339–347.
- Kerkhoff, G., & Schenk, T. (2012). Rehabilitation of neglect: An update. *Neuropsychologia*, *50*, 1072–1079.
- Khan, A. Z., Blangero, A., Rossetti, Y., Salemme, R., Luauté, J., Deubel, H., Schneider, W. X., Laverdure, N., Rode, G., Boisson, D., & Pisella, L. (2009). Parietal damage dissociates saccade planning from presaccadic perceptual facilitation. *Cerebral Cortex*, *19*, 383–387.
- Malhotra, P., Mannan, S., Driver, J., & Husain, M. (2004). Impaired spatial working memory: One component of the visual neglect syndrome? *Cortex; a Journal Devoted To the Study of the Nervous System and Behavior*, *40*, 667–676.
- Marshall, J. C., & Halligan, P. W. (1989). Does the midsagittal plane play any privileged role in “left” neglect? *Cognitive Neuropsychology*, *6*, 403–422.
- Montagnini, A., & Castet, E. (2007). Spatiotemporal dynamics of visual attention during saccade preparation: Independence and coupling between attention and movement planning. *Journal of Vision*, *7*, 8.1–16.
- Pisella, L., & Mattingley, J. B. (2004). The contribution of spatial remapping impairments to unilateral visual neglect. *Neuroscience and Biobehavioral Reviews*, *28*, 181–200.
- Rizzolatti, G., Riggio, L., Dascola, I., & Umiltà, C. (1987). Reorienting attention across the horizontal and vertical meridians: Evidence in favor of a premotor theory of attention. *Neuropsychologia*, *25*, 31–40.
- Rolfs, M., Jonikaitis, D., Deubel, H., & Cavanagh, P. (2011). Predictive remapping of attention across eye movements. *Nature Neuroscience*, *14*, 252–256.

- Saj, A., Pierce, J., Caroli, A., Ronchi, R., Thomasson, M., & Vuilleumier, P. (2020). Rightward exogenous attentional shifts impair perceptual memory of spatial locations in patients with left unilateral spatial neglect. *Cortex; a Journal Devoted To the Study of the Nervous System and Behavior*, 122, 187–197.
- Saj, A., Verdon, V., Hauert, C.-A., & Vuilleumier, P. (2018). Dissociable components of spatial neglect associated with frontal and parietal lesions. *Neuropsychologia*, 115, 60–69.
- Smith, D. T., & Schenk, T. (2012). The premotor theory of attention: Time to move on? *Neuropsychologia*, 50, 1104–1114.
- Striemer, C., Blangero, A., Rossetti, Y., Boisson, D., Rode, G., Vighetto, A., Pisella, L., & Danckert, J. (2007). Deficits in peripheral visual attention in patients with optic ataxia. *Neuroreport*, 18, 1171–1175.
- Van der Stigchel, S., & Hollingworth, A. (2018). Visuospatial working memory as a fundamental component of the eye movement system. *Current Directions in Psychological Science*, 27, 136–143.
- Van der Stigchel, S., & Nijboer, T. C. W. (2010). The imbalance of oculomotor capture in unilateral visual neglect. *Consciousness and Cognition*, 19, 186–197.
- Van der Stigchel, S., & Nijboer, T. C. W. (2018). Temporal order judgements as a sensitive measure of the spatial bias in patients with visuospatial neglect. *Journal of Neuropsychology*, 12, 427–441.
- Vuilleumier, P., Sergent, C., Schwartz, S., Valenza, N., Girardi, M., Husain, M., & Driver, J. (2007). Impaired perceptual memory of locations across gaze-shifts in patients with unilateral spatial neglect. *Journal of Cognitive Neuroscience*, 19, 1388–1406.
- Zhao, M., Gersch, T. M., Schnitzer, B. S., Doshier, B. A., & Kowler, E. (2012). Eye movements and attention: The role of pre-saccadic shifts of attention in perception, memory and the control of saccades. *Vision Research*, 74, 40–60.